

Mi-T-M[®] CORPORATION

8650 Enterprise Drive, Peosta IA 52068
319-556-7484 / Fax 319-556-1235

PARTS LIST FOR HSP-2003-3MGH/3MGV (After Serial #26203)

ENGINE OIL GRADE:

HONDA:

VANGUARD:

SAE 10W-30

ABOVE 40°F=SAE30

BELOW 40°F=SAE10W-30

ENGINE OIL CAPACITY:

HONDA:

VANGUARD:

20 OZ.

24 OZ.

PUMP OIL GRADE:

Mi-T-M PUMP OIL AW-4085-0016

PUMP OIL CAPACITY:

14 OZ.

FUEL NOZZLE:

1.25 60°B DELAVAN

BTU INPUT:

205,000 / HOUR

PRESSURE NOZZLE SIZE:

3.5

This Parts Listing has been compiled for your benefit. You can be assured your hot water pressure washer was constructed and designed with quality and performance in mind. Each component has been rigorously tested to insure the highest level of quality.

The contents of this Parts Listing are based on the latest product information available at the time of publication. The manufacturer reserves the right to make changes in price, color, materials, equipment, specifications or models at any time without notice.

WARNING

THIS IS A PROFESSIONAL HIGH PRESSURE, HOT WATER PRESSURE WASHER. CAUTION SHOULD BE OBSERVED WHEN USING OR REPAIRING THIS UNIT! READ AND FOLLOW THE SAFETY WARNINGS LISTED BELOW BEFORE ATTEMPTING ANY REPAIRS ON THIS PRESSURE WASHER!

SAFETY WARNINGS

1. NEVER alter or modify the equipment. Be sure any accessory items and system components being used will withstand the pressure developed. Use only genuine manufacturer parts for repair of your pressure washer. Failure to do so can cause hazardous operating conditions and will VOID warranty.
2. NEVER make adjustments on machinery while the unit is connected to the engine without first removing the ignition cable from the spark plug. Turning over the machinery by hand during adjustment or cleaning might start the engine and machinery with it, causing serious injury to the operator.
3. Know how to stop and bleed pressures quickly. Be thoroughly familiar with controls.
4. Before servicing the unit, turn unit off, relieve the water pressure and allow the unit to cool down. Do not make repairs while the unit is running. Service in a clean, dry, flat area. Block the wheels to prevent the unit from moving. Be especially careful to properly dispose of any flammable materials.
5. After testing the machine, DO NOT leave the pressurized unit unattended. Shut off the unit and release trapped pressure before leaving.

TABLE OF CONTENTS

SPECIFICATIONS	3
FLOW CHART	4
EMF SYSTEM	4
GENERAL THEORY OF OPERATION	5
DECAL PLACEMENT	6
FRAME	8
ENGINE/ PUMP ASSEMBLY	10
HIGH PRESSURE PUMP (3-0193)	12
PUMP SERVICE GUIDE	14
UNLOADER/ MANIFOLD ASSEMBLY	16
UNLOADER (850-0252)	18
PRESSURE SETTING & TROUBLESHOOTING THE UNLOADER	19
PRESSURE SWITCH (22-0171)	20
DETERGENT INJECTOR (50-0052)	21
COIL DRAIN PLUG (850-0218)	21
HEAT EXCHANGER/ EMF SYSTEM	22
BOILER ASSEMBLY (850-0224)	24
GUN (850-0179) & ADJUSTABLE PRESSURE DUAL LANCE (850-0185)	26
FUEL TANK (850-0214)	28
FUEL PUMP (3-0129)	30
FUEL SOLENOID (44-0098)	31
EMF SYSTEM (850-0239)	32
WIRING SCHEMATIC	34
WIRING DIAGRAM	35

SPECIFICATIONS

HSP-2003-3MGH/GV

MODEL NUMBER	HSP-2003-3MGH	HSP-2003-3MGV
Operating Pressure (PSI/Bar):	2000/ 138 (+/- 5%)	
Water Volume (GPM/lpm):	2.5/9.5 (+/- 5%)	
Outlet Water Temperature (F/C):	130°F/ 54°C (+/- 20°F) rise above inlet ambient (210°F/ 99°C maximum)	
Engine:	Honda	Briggs & Stratton Vanguard
Horsepower	5.5	6.0
Engine Type	Four Stroke, Overhead Valve, Single Cylinder	
Oil Type	SAE10W-30	Above 40°F=SAE30/ Below 40°F=SAE 10W-30
Oil Capacity (oz./liter)	20/.6	24/.7
Low Oil Protection	Oil Alert™	Oil Guard™
Fuel Type	Unleaded Gasoline 86 Octane Minimum	
Fuel Capacity (gal./liter)	.95/ 3.6	1.05/3.97
Starting	Recoil Rope	
Maximum No Load RPM	3600 (+/- 100)	
High Pressure Pump:	Direct Driven, Oil Bath, Triplex Piston	
Oil Type	Mi-T-M Pump Oil #AW-4085-0016	
Oil Capacity (oz./liters)	14/ .41	
Plungers	Ceramic	
Manifold	Forged Brass	
Valves	Stainless Steel	
Unloader	Preset	
Inlet Water Strainer	Removable Clear Bowl for inspection and cleaning of Stainless Steel Screen	
Heat Dump Valve	Relieves heated water during unloader bypass stage	
Detergent Injector:	Adjustable Low Pressure downstream from pump	
Burner Fuel System:		
Fuel Type	No.1 or No.2 Fuel Oil, Diesel or Kerosene	
Fuel Capacity (gal./liters)	4/15	
Fuel Filter/ Water Separator	Spin on (10 micron) filter/ E-Z water drain	
Fuel Pump	Two Line, Single Stage	
Fuel Pressure (PSI/ BAR)	145/ 10	
Fuel Nozzle	1.25 60° B Delavan	
Fuel Consumption (GPH/ LPH)	1.48 GPH Continuous Burning	
Electro Magnetic Firing (EMF) System:	Belt Driven (Patent Pending)	
Ignition	Transistorized Magneto	
Control Voltage	12 Volt DC	
Blower	Forced Air	
Heat Exchanger:	Vertical, Top fired, Dual Spiral Coil	
BTU Input	205,000	
Efficiency	80-83% with #2 Fuel Oil/ Diesel	
Smoke Density	0-3 per ASTM D2156	
Controls:		
On/ Off Switch	Industrial grade cam switch	
Pressure Switch	Shuts off burner fuel supply upon trigger release	
High Limit Switch	Shuts off burner fuel supply when outlet water temp. exceeds 210°F/ 99°C	
Fuel Solenoid:	12 Volt	
Safety Relief:	Relieves excess system pressure	
Unit Net Weight (Lbs/kg):	265/120	270/123
Unit Shipping Weight (Lbs/kg):	381/173	386/175
Unit Net Dimension (In/cm):	37.5L x 29.5W x 37.5H/95L x 75W x 95H	
Unit Shipping Dimension (In/cm):	46.5L x 31.5W x 48.5H/118L x 80W x 123H	

FLOW CHART

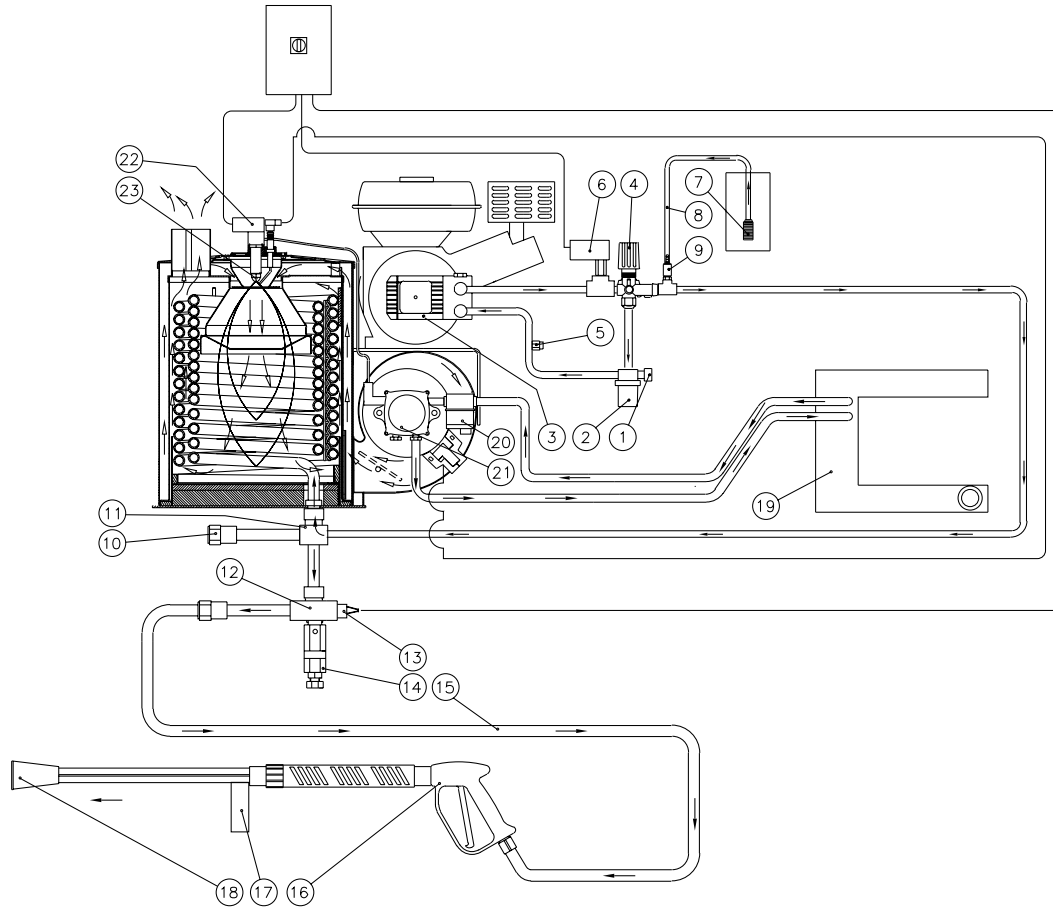

OMHSP091-120998-BAR

EMF SYSTEM

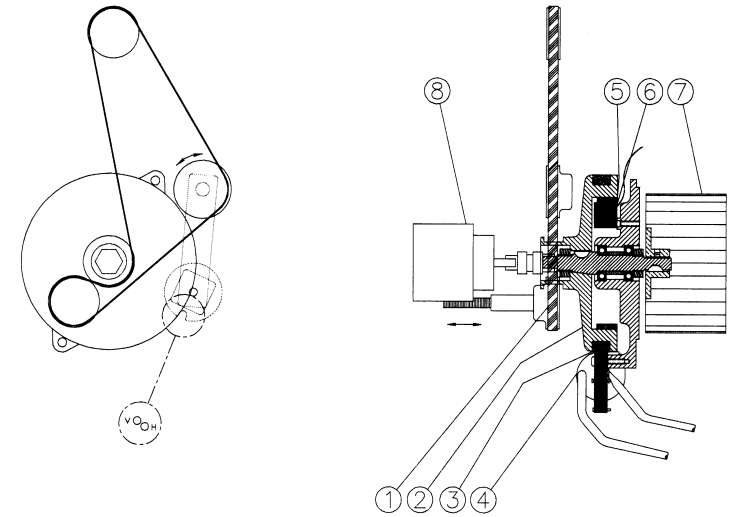

OMHSP008/012494/BAR

GENERAL THEORY OF OPERATION

WATER FLOW: Connect a pressurized water source to the INLET GARDEN HOSE CONNECTION (1) and turn on the water supply. The water will flow through a WATER STRAINER (2) which has a clear inspection bowl.

The water then travels into the TRIPLEX HIGH PRESSURE PUMP (3) which has an UNLOADER (4) that bypasses the water when the trigger gun is closed. To protect the pump from heated water during this bypass stage, a HEAT DUMP VALVE (5) will open at 140°F/60°C allowing the heated water to escape. The Heat Dump Valve automatically resets when the water cools. The PRESSURE SWITCH (6) controls the fuel supply to the burner.

When using detergents, the solution passes through the DETERGENT STRAINER (7) located on the DETERGENT HOSE (8). The detergent solution then travels into the ADJUSTABLE LOW PRESSURE DETERGENT INJECTOR (9).

From there, the water may be allowed to flow out of the DRAIN PLUG (10) or through the HEAT EXCHANGER INLET (11) where it is heated when the burner is on. As the water exits the HEAT EXCHANGER OUTLET (12), it enters a safety system which protects the operator from danger. The safety system contains a HIGH TEMPERATURE LIMIT SWITCH (13) which senses the water temperature and shuts off the fuel supply to the burner if it gets too hot. If the unloader fails to by pass the water or the burner remains on when the trigger gun is closed, the SAFETY RELIEF (14) will relieve and allow water to exit safely.

The heated water then flows through the HIGH PRESSURE HOSE (15) and to the TRIGGER GUN ASSEMBLY (16) which allows the operator to control the water spray. When the trigger gun is open, the water flows through the ADJUSTABLE PRESSURE DUAL LANCE (17) and exits the NOZZLE (18).

FUEL FLOW: The Fuel Pump draws fuel from the FUEL TANK (19) through a replaceable FUEL FILTER/WATER SEPARATOR (20) and into the FUEL PUMP (21). Fuel exits the fuel pump, into a FUEL SOLENOID VALVE (22) which controls fuel flow to the FUEL NOZZLE (23) where it ignites and burns in the heat exchanger.

EMF SYSTEM: The patent pending Electro Magnetic Firing (EMF) System is an integrated system which gives all the requirements for combustion.

The BELT (1) from the power source turns the HUB (2) which has two EXTERIOR MAGNETS (3) attached. As these magnets spin past the IGNITION MODULE (4), a magnetic flux is created from which the ignition module produces a high voltage. This voltage arcs across the electrodes giving the spark that is needed for ignition.

This hub has an INTERNALLY MOUNTED MAGNET (5) which spins past a STATOR (6) that produces the voltage that controls the fuel supply to the heat exchanger. In addition to this, the hub also spins the BLOWER FAN (7) that forces the air into and through the heat exchanger.

The FUEL PUMP (8) is also connected the hub by means of a flexible coupler.

DECAL PLACEMENT

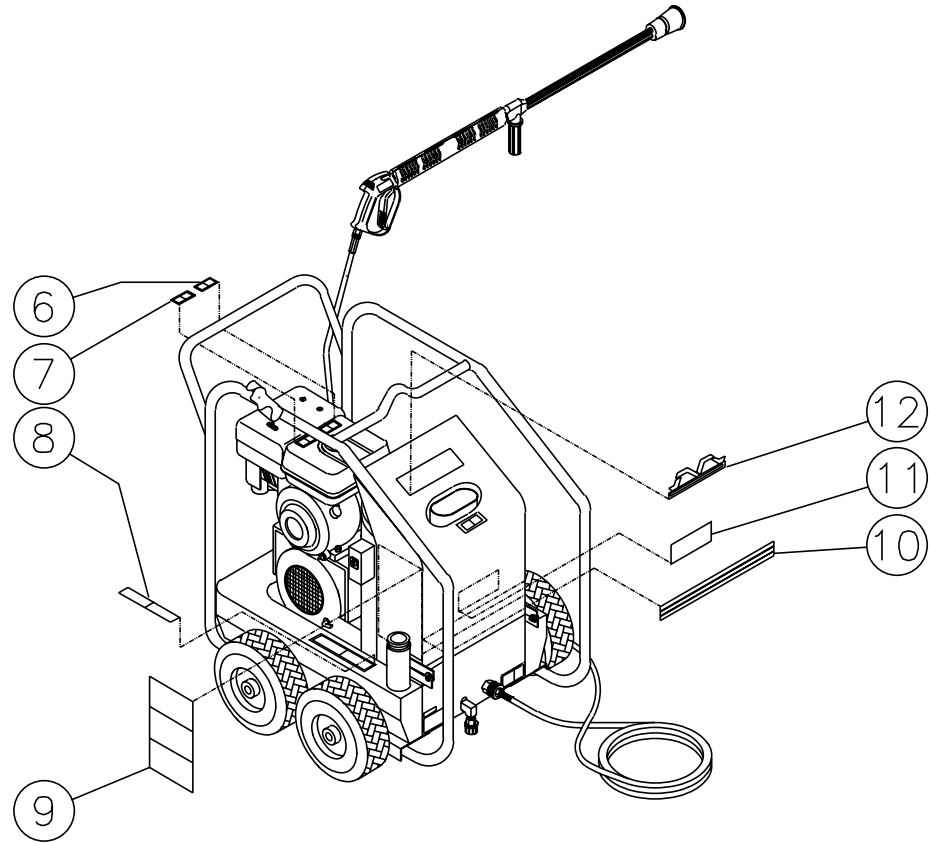
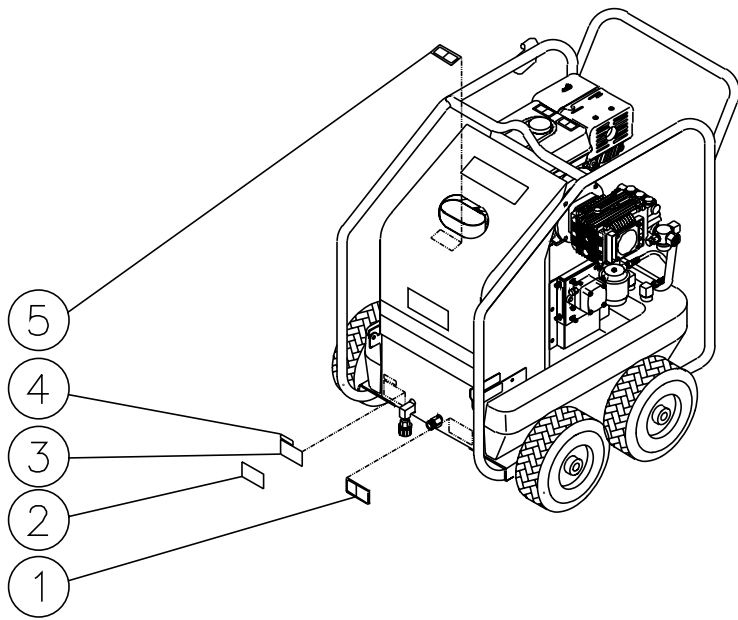

HSP-2003-3MGH/GV-022299-BAR

DECAL PLACEMENT			
REF. #	DESCRIPTION	PART #	QTY.
1	Decal- Warning: Don't Modify Plumbing (E/S)	34-0852	1
2	Decal- Clear Laminate	N/A	1
3	Decal- Data Plate	N/A	1
4	Serial Number	N/A	1
5	Decal- Warning: Hot Coil Exhaust (E/S)	34-0808	1
6	Decal- Allow to Cool (E/S)	34-0599	1
7	Decal- Hot Surface (E/S)	34-0598	1
8	Decal- Risk of Fire (E/S)	34-0806	1
9	Decal- Warning/ Caution/ Operation (E/S)	34-0847	1
10	Decal- Stripe	34-0560	1
11	Decal-White Die Cut	34-0551	1
12	Plastic Mi-T-M Logo	62-0087	1

FRAME

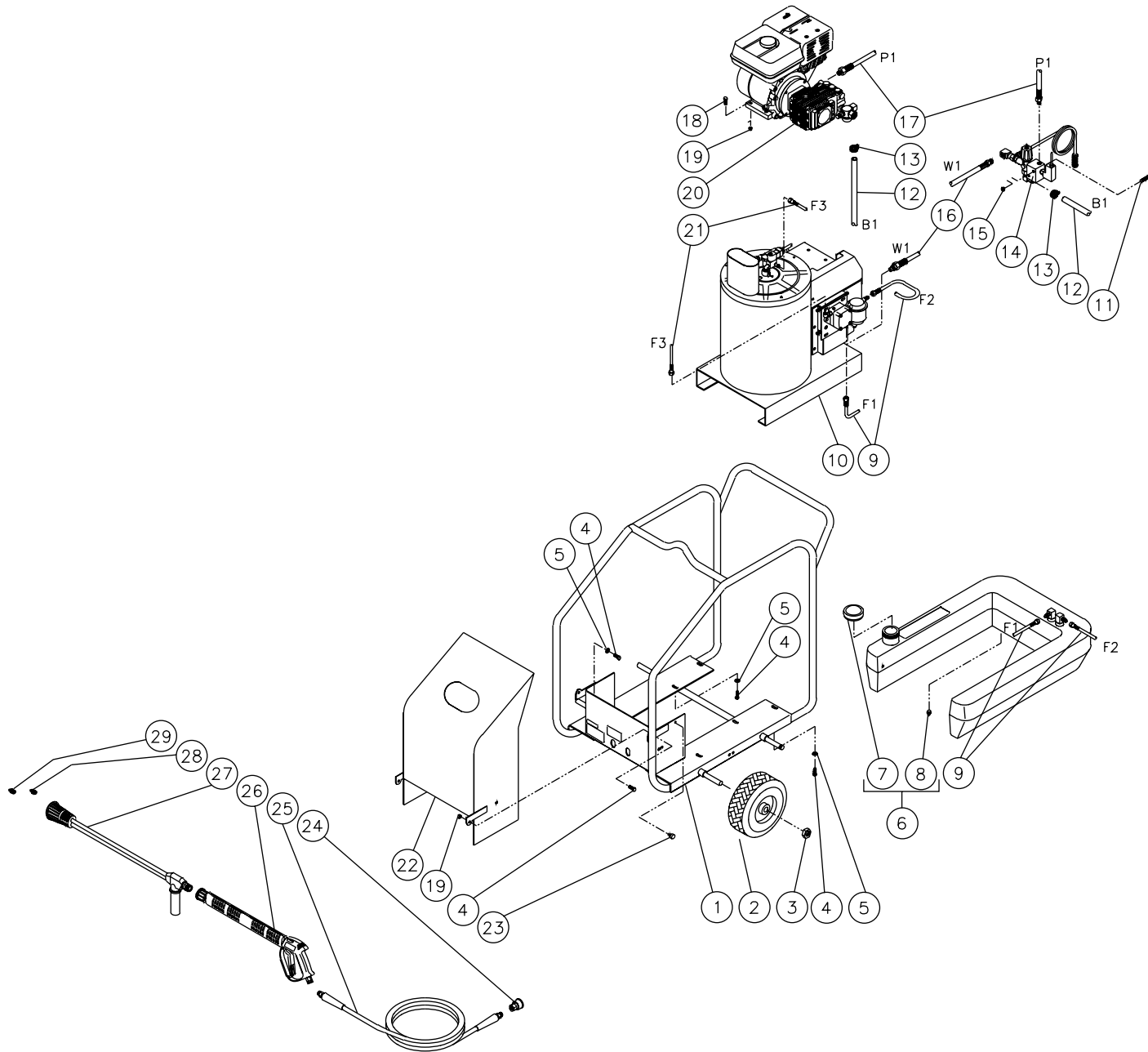

HSP096-022299-BAR

FRAME									
REF. #	DESCRIPTION	PART #	QTY.		REF. #	DESCRIPTION	PART #	QTY.	
1	Frame Assembly	5-9002A01	1		16	High Pressure Hose Assembly	15-0199	1	
2	Wheel	14-0017	4		17	High Pressure Hose Assembly	15-0194	1	
3	Jam Nut	30-0117	4		18	Bolt	27-9525	4	
4	Bolt	27-9524	12		19	Hex Nut	30-3023	6	
5	Flatwasher	28-0022	10		20	Engine/ Pump Assembly (See exploded Drawing)	N/A Sep.	1	
6	Fuel Tank Assembly (Includes 7, 8)	850-0214	1		21	Fuel Line	33-0217	1	
7	Fuel Cap	12-0033	1		22	Hood Assembly	850-0164	1	
8	Plug	23-0296	1		23	Screw Cover	62-0057	1	
9	Fuel Hose	15-0147	2		24	Screw Connect	17-0035	1	
10	Heat Exchanger/ EMF System Assembly (See exploded Drawing)	N/A Sep.	1		25	Hose Assembly	15-0146	1	
11	Bolt	27-0526	2		26	Gun/ Lance Assembly	850-0179	1	
12	Hose *(Two Feet Required)	15-0007	1		27	Dual Lance Assembly- 36"	850-0185	1	
13	Hose Clamp	42-0011	2		28	Nozzle- 1503.5	18-0254	1	
14	Unloader/ Manifold Assembly (See exploded Drawing)	N/A Sep.	1		29	Nozzle- 4060	18-0110	1	
15	Hex Nut	30-0157	2		*Must Order in One Foot Lengths				

ENGINE/PUMP ASSEMBLY

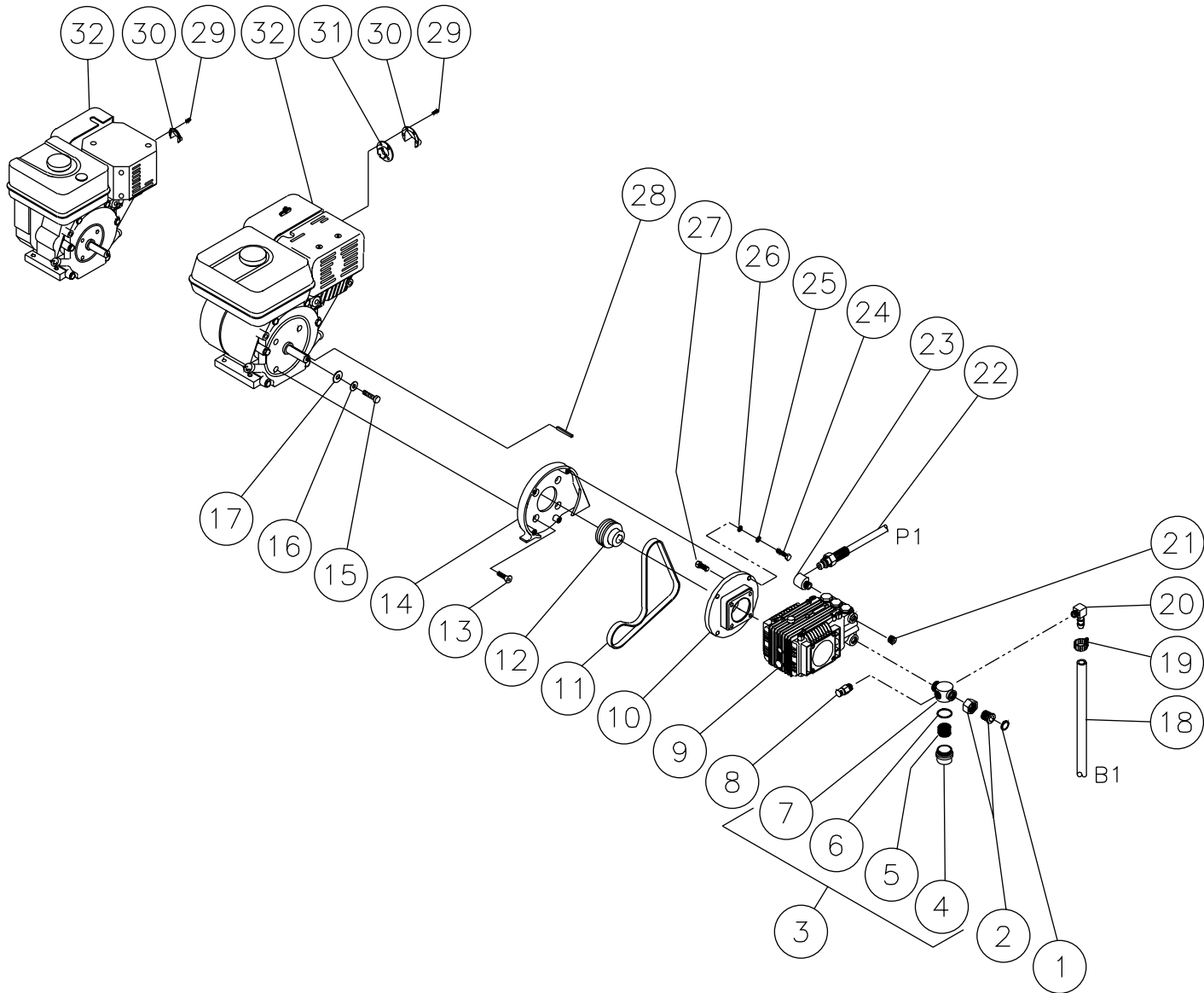

ENGINE/ PUMP ASSEMBLY									
REF. #	DESCRIPTION	PART #	QTY. 3MGH	QTY. 3MGV	REF. #	DESCRIPTION	PART #	QTY. 3MGH	QTY. 3MGV
1	Hose Gasket	26-0001	1	1	19	Hose Clamp	42-0011	1	1
2	Hose Swivel	23-0095	1	1	20	Elbow	23-0119	1	1
3	Strainer Complete (Includes 4-7)	19-0096	1	1	21	Plug	23-0244	1	1
4	Strainer Bowl	19-0103	1	1	22	High Pressure Hose	15-0194	1	1
5	Stainless Steel Screen	19-0104	1	1	23	Elbow	23-0242	1	1
6	Strainer Gasket	25-0056	1	1	24	Bolt	27-0118	4	4
7	Strainer Body	19-0105	1	1	25	Lockwasher	29-0008	4	4
8	Heat Dump Valve	22-0208	1	1	26	Flatwasher	28-0023	4	4
9	High Pressure Pump	3-0193	1	1	27	Bolt	27-8432	4	4
10	Flange/ Pump Adapter	38-0054	1	1	28	Key	43-0073	1	1
11	Belt	11-0037	1	1	29	Screw- Honda	27-3093	2	-
12	Sheave	10-0076	1	1	-	Screw- Vanguard	27-3094	-	2
13	Bolt	27-0418	4	4	30	Muffler Deflector- Honda	45-0051	1	-
14	Adapter Plate	38-0044	1	1	-	Muffler Deflector- Vanguard	45-0050	-	1
15	Bolt	27-0091	1	1	31	Muffler Guide- Honda	45-0052	1	-
16	Lockwasher	29-0007	1	1	32	Engine- 5.5 H.P. Honda	1-0013	1	-
17	Flatwasher	28-0003	1	1	-	Engine- 6.0 H.P. Vanguard	1-0069	-	1
18	Hose *(Two Feet Required)	15-0007	1	1	*Must Order in One Foot Lengths				

HIGH PRESSURE PUMP (3-0193)

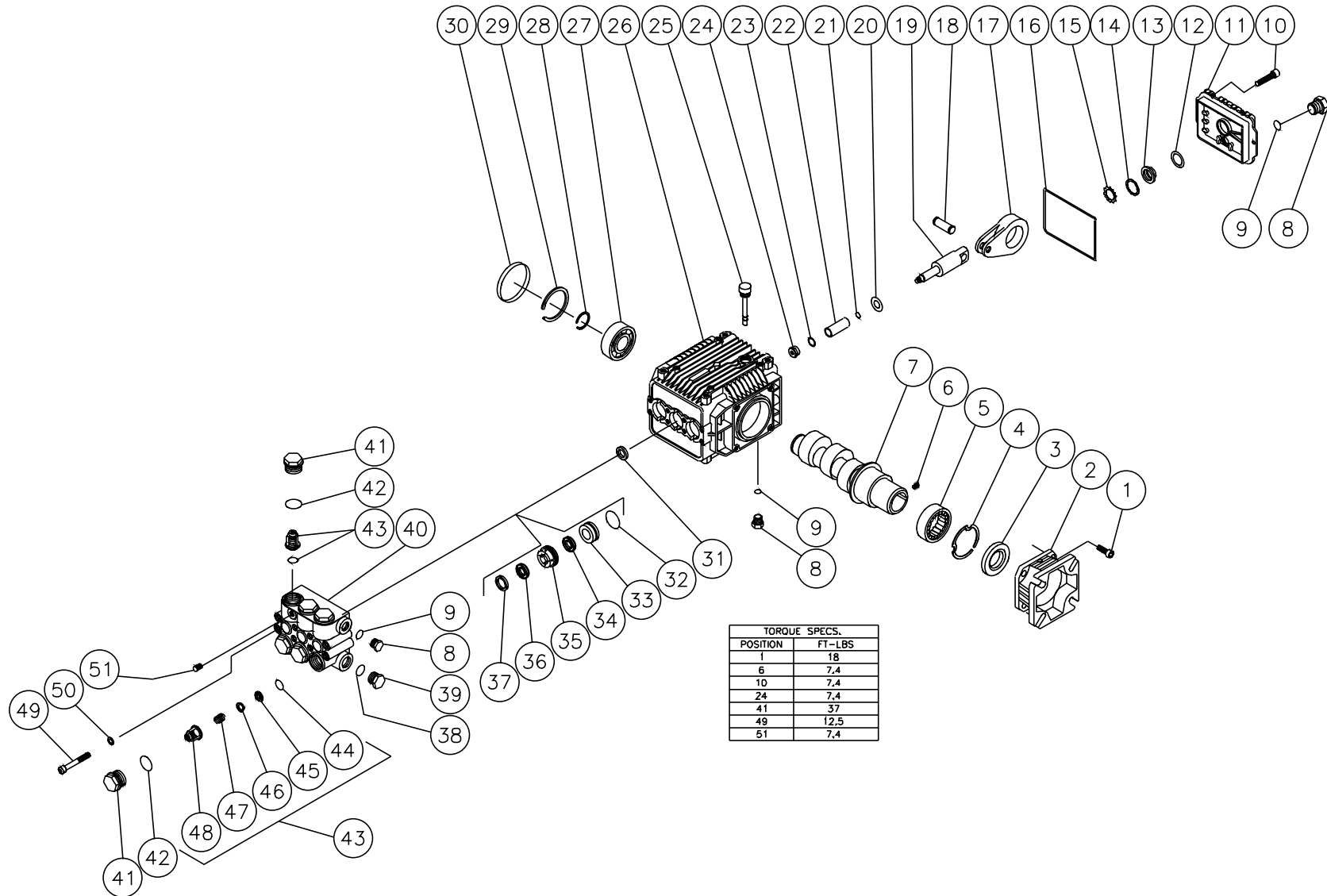

TORQUE SPECS.	
POSITION	FT-LBS
1	18
6	7.4
10	7.4
24	7.4
41	37
49	12.5
51	7.4

3-0193-051999-RD

HIGH PRESSURE PUMP (3-0193)							
REF.	DESCRIPTION	PART #	QTY.	REF.	DESCRIPTION	PART #	QTY.
1	Bolt	27-8432	4	28	Retaining Ring	46-0732	1
2	Flange	46-0715	1	29	Retaining Ring	46-0676	1
3	Oil Seal	26-0192	1	30	Bearing Cap	46-0725	1
4	Retaining Ring	46-0667	1	31	Oil Seal	26-0193	3
5	Bearing	48-0059	1	32	O-ring (See 70-0181)	N/A Sep.	3
6	Set Screw	27-8886	1	33	Retainer	46-0726	3
7	Crankshaft	46-0718	1	34	Low Pressure Seal (See 70-0181)	N/A Sep.	3
8	Plug	39-0086	1	35	Packing Retainer	46-0728	3
9	O-ring	25-0325	3	36	V-Packing (See 70-0181)	N/A Sep.	3
10	Bolt	27-8888	6	37	Support Ring (See 70-0182)	N/A Sep.	3
11	Crankcase Cover	46-0719	1	38	O-ring	25-0372	1
12	O-ring	25-0370	1	39	Plug	39-0088	1
13	O-ring Sight Glass	46-0670	1	40	Manifold	46-0730	1
14	Reflector	46-0824	1	41	Valve Cap	39-0087	6
15	Retainer	46-0671	1	42	O-ring	25-0160	6
16	O-ring	25-0398	1	43	Single Valve Assembly (Inc. 44-48)	N/A Sep.	6
17	Connecting Rod	46-0720	3	44	O-ring (See 70-0161)	N/A Sep.	6
18	Piston Pin	46-0721	3	45	Valve Seat (See 70-0161)	N/A Sep.	6
19	Plunger Rod	46-0722	3	46	Valve Plate (See 70-0161)	N/A Sep.	6
20	Washer	28-1022	3	47	Valve Spring (See 70-0161)	N/A Sep.	6
21	O-ring	25-0371	3	48	Valve Cage (See 70-0161)	N/A Sep.	6
22	Piston	46-0723	3	49	Bolt	27-8875	8
23	Washer	26-0187	3	50	Lockwasher	29-0153	8
24	Nut	30-6016	3	51	Plug	39-0097	1
25	Oil Dipstick	39-0090	1		Seal Kit (3 each 33, 35, 37)	70-0181	
26	Crankcase	46-0724	1		Support Rings (3 each 38)	70-0182	
27	Bearing	48-0063	1		Valve Kit (6 each 46-50)	70-0161	

PUMP SERVICE GUIDE

USE THE PARTS LIST ON THE PREVIOUS PAGE TO REORDER PARTS NEEDED TO SERVICE YOUR PUMP.

Fig. A

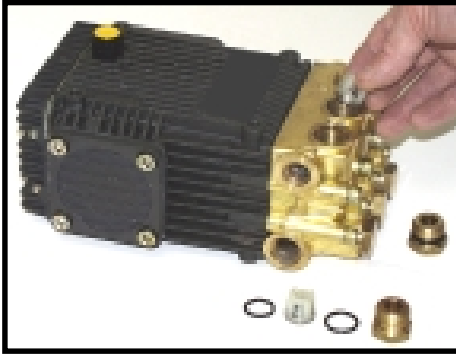

REPLACING THE VALVE ASSEMBLY:

1. In order to maintain optimum pump performance, replace all the valves at one time. The valve assemblies can be replaced without disrupting plumbing.
2. Remove the valve cap from the manifold.
3. Inspect the o-ring on the valve cap for deterioration. Replace if necessary.
4. Remove the valve assembly from the valve cavity (Fig. A).
5. Remove the o-ring inside the bottom of the valve cavity. Check for signs of severe deterioration of the o-ring. This could reflect excessive wear in the valve cavity of the manifold which is a *normal* occurrence in pumps with an extended life (over 1000 hours). Check the manifold and replace if necessary. (Note: *Normal* wear in the manifold is not covered under warranty.)
6. Install the new o-ring into the bottom of the valve cavity, then place the new valve assembly into the valve cavity.
7. Reinstall the valve cap and torque to 37 Ft/lbs (444 in/lbs).

Fig. B

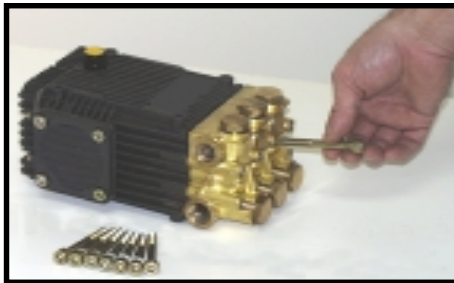

REMOVING THE MANIFOLD:

1. Remove the head bolts on the manifold (Fig. B).

⚠ CAUTION **RISK OF DAMAGE**

USE CAUTION NOT TO DAMAGE THE PLUNGERS WHEN REMOVING THE MANIFOLD HEAD FROM THE CRANKCASE.

Fig. C

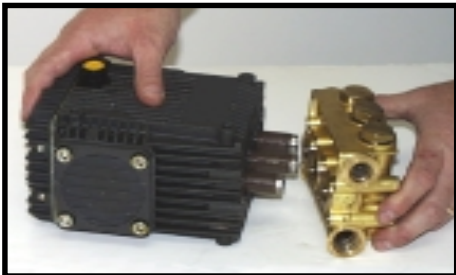

2. Pull the manifold head from the crankcase (Fig. C). Rotate the crankshaft or tap the manifold head lightly with a rubber mallet to loosen if necessary.

NOTE: The V-packing assemblies may come off with the manifold head. If this happens, reinsert the V-packings in the order given in the "V-Packing Cross Section" illustration shown on the following page.

Fig. D

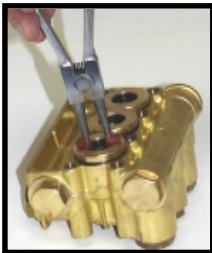

Fig. E



Fig. F

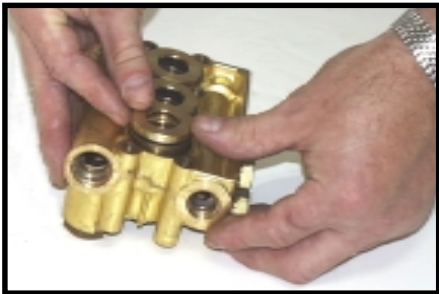

Fig. G

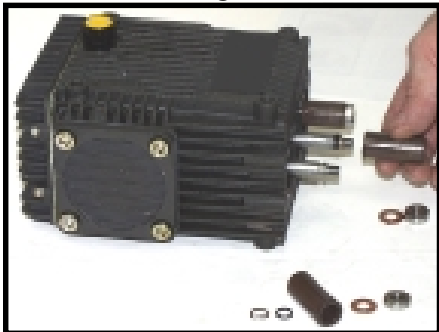
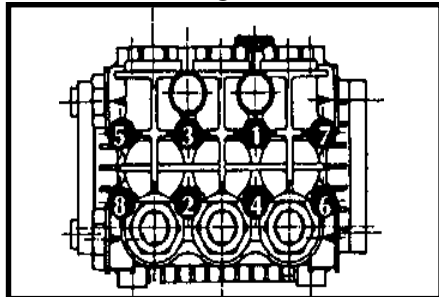
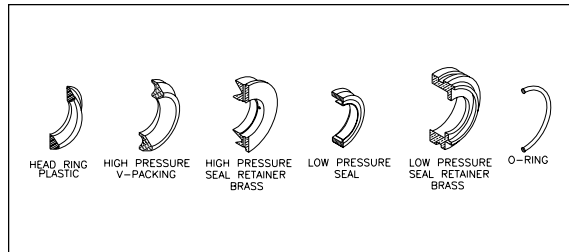

Fig. H



V-PACKING CROSS SECTION



REPLACING V-PACKINGS:

1. In order to maintain optimum pump performance, replace all the V-Packings at one time. The manifold must be removed from the crankcase before performing this procedure. Use of an extractor is highly recommended for V-packing removal.
2. Insert the extractor through the center of the V-packing (Fig. D) and pull the V-Packing from the manifold (Fig. E).
3. Install the V-Packings in the order shown in the drawing at left.
NOTE: A film of grease on the o-rings ensure easier installation.
4. Move on to replace plungers if necessary. If plungers do not need replacing, reinstall the manifold head as described in "Reinstalling the Manifold" (Fig. F).

REPLACING PLUNGERS:

1. Remove piston nut and washer from the piston rod.
2. Examine the plungers for cracks and wear. Replace if necessary.
3. Remove the plunger (Fig. G). If the slinger washer comes off with the plunger, replace it before installing the new plunger.
4. Install the replacement parts over the piston guide in the order given:
-Anti-extrusion ring, O-ring, Plunger, Washer.

NOTE: A film of grease on the o-ring ensures easier installation.

5. Apply thread sealant to the piston guide threads.
6. Install the piston nut and torque to 7.4 Ft/lbs (89 in/lbs).

REINSTALLING THE MANIFOLD:

1. Apply a coat of grease to each plunger and reinstall the manifold head, taking care not to damage the plungers.
2. Install and tighten the head bolts as shown in the sequence at left (Fig. H). Use your fingers first, then at half the torque specified for your pump. Perform a final torque to 12.5 Ft/lbs (150 in/lbs).

UNLOADER/MANIFOLD ASSEMBLY

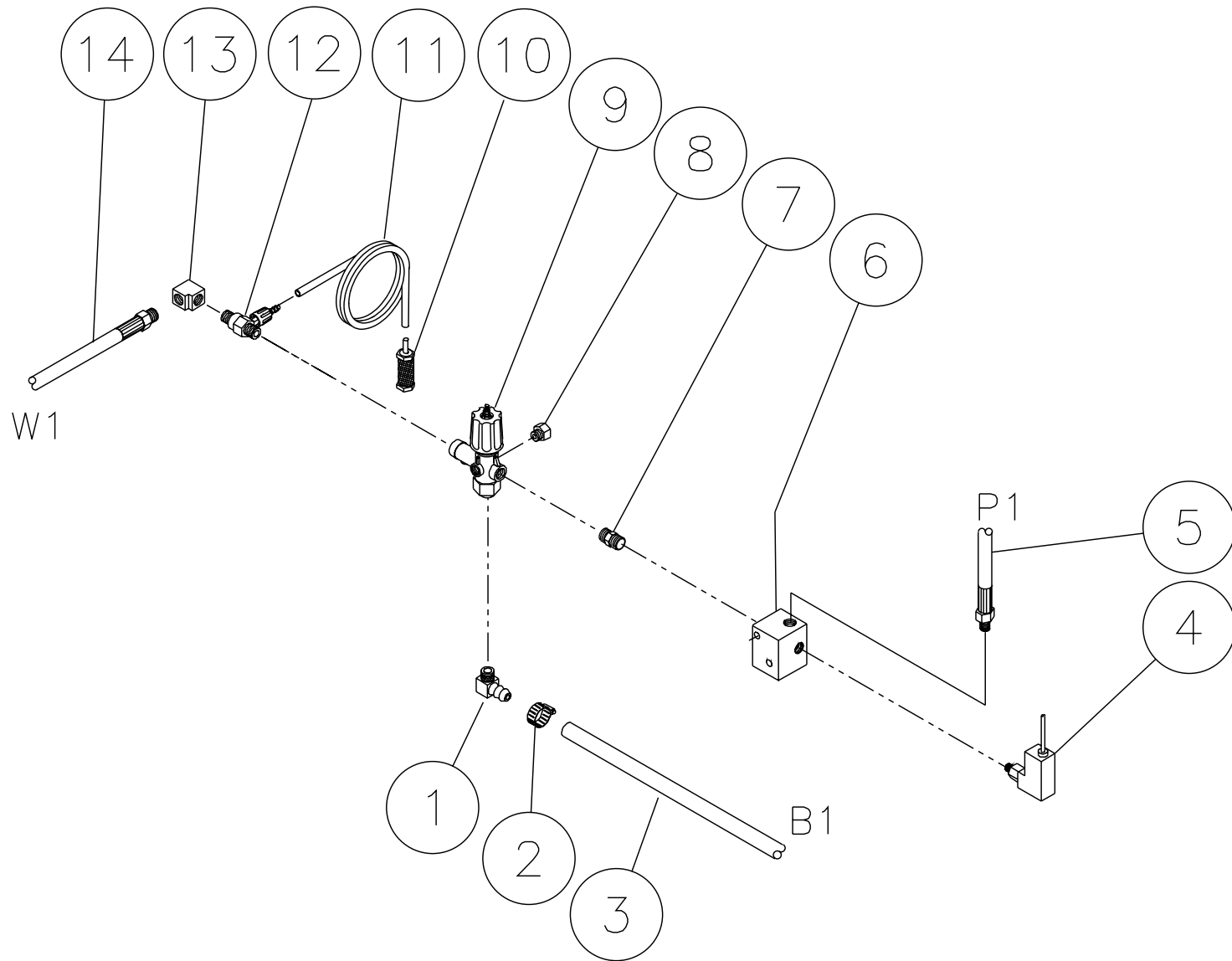

UNLOADER/ MANIFOLD ASSEMBLY			
REF. #	DESCRIPTION	PART #	QTY.
1	Elbow	23-0119	1
2	Hose Clamp	42-0011	1
3	Hose *(Two Feet Required)	15-0007	1
4	Pressure Switch	22-0171	1
5	High Pressure Hose Assembly	15-0194	1
6	Manifold Block	51-0025	1
7	Hex Nipple	24-0010	1
8	Plug	23-0238	1
9	Unloader Assembly	850-0252	1
10	Detergent Stainer	19-0050	1
11	Detergent Hose *(Six Feet Required)	15-0021	1
12	Detergent Injector	50-0052	1
13	Elbow	23-0307	1
14	High Pressure Hose Assembly	15-0199	1
*Must Order in One Foot Lengths			

UNLOADER (850-0252)

OMGEN163-101298-BAR

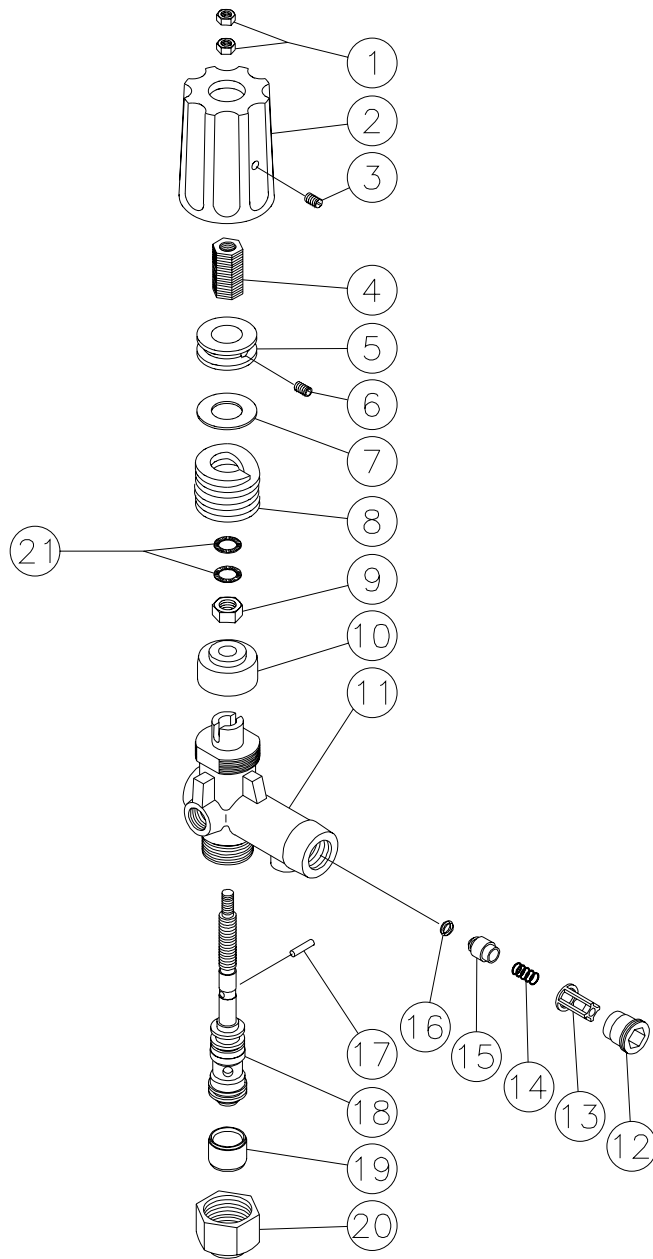

UNLOADER (850-0252)			
REF. #	DESCRIPTION	PART #	QTY.
1	Hex Nut	8-0362	2
2	Cover	7-0098	1
3	Set Screw	27-4280	1
4	Adjusting Insert- Brass	8-0363	1
5	Adjustment Nut	8-0364	1
6	Set Screw	8-0365	1
7	Glide Ring	8-0366	1
8	Spring	49-0104	1
9	Hex Nut	8-0367	1
10	Bushing	8-0368	1
11	Unloader Body	8-0369	1
12	Retainer	8-0269	1
13	Valve Housing	8-0104	1
14	Spring	49-0023	1
15	Valve	8-0105	1
16	O-ring	25-0036	1
17	Cylinder Pin	8-0372	1
18	Piston Repair Kit	70-0243	1
19	Spacer	8-0371	1
20	Stop Nut	8-0157	1
21	Washer	29-0154	2
	Check Valve Repair Kit (Includes 13-16)	70-0244	
	Unloader Complete	850-0252	

OMGEN163-101298-BAR

PRESSURE SETTING & TROUBLESHOOTING THE UNLOADER

TOOLS NEEDED:

5000 PSI gauge
2.5mm Allen Wrench
Small Flathead Screw Driver
Adjustable Wrench

TO SET MAXIMUM SPRAY PRESSURE AND BYPASS PRESSURE:

Refer to Parts Listing on pg.18. Install the test gauge in the auxiliary port on unloader or in discharge line after the unloader valve. With the pump operating but the trigger gun off, loosen the SET SCREW (3) and remove the COVER (2). Remove both HEX NUTS (1) and set aside. Using the 2.5 mm Allen wrench, loosen the SET SCREW (6) and turn the ADJUSTING NUT (5) with adjustable wrench **counterclockwise** so that it is flush with top of the ADJUSTING INSERT (4). Tighten the SET SCREW (6). With adjustable wrench, turn the ADJUSTING NUT (5) **clockwise** until the ADJUSTING INSERT (4) bottoms out against the HEX NUT (9). Loosen the SET SCREW (6) with 2.5 mm Allen wrench, so that the ADJUSTING NUT (5) turns freely but does not turn the ADJUSTING INSERT (4). With proper nozzle installed in spray gun, squeeze trigger and turn ADJUSTING NUT (5) **clockwise** to desired maximum spray pressure. Then tighten the SET SCREW (6) securely and release the trigger on the trigger gun. Squeeze and release trigger several times to verify consistency of spray pressure setting. Turn the ADJUSTMENT NUT (5) **counterclockwise** two full turns and then **clockwise** again until tight. Squeeze trigger and verify desired pressure setting. Spray pressure should fall within 5% of original setting. Bypass pressure (the reading on the gauge when the trigger is released) should exceed the spray pressure by approximately 15-20%. If valve fails to repeat within specifications, repeat the steps above and assure all final settings are tight. Install one HEX NUT (1) and tighten against the ADJUSTING INSERT (4). Install the second HEX NUT (1) and tighten securely against the first. Insert the COVER (2) and tighten the SET SCREW (3).

TROUBLESHOOTING:

SYSTEM WILL NOT COME UP TO FULL DESIGNATED PRESSURE:

- * Spray nozzle worn or nozzle orifice is too large in relation to pump flow rate.
- * Adjusted improperly. Refer to pressure adjustment section for proper procedures.
- * Bypass valve (within unloader) is obstructed or leaking. Remove and clean bypass cartridge or replace. Replace with #850-0252.
- * Flow rate of pump inadequate. Assure designated flow rate of pump is adequate in relation to spray nozzle size.

PRESSURE SPIKES IN DISCHARGE LINE DURING BYPASS MODE:

- * Pressure adjustment too tight. Refer to pressure adjustment section for proper adjustment procedures.

UNLOADER CYCLES WHILE IN BYPASS MODE:

- * External leak on unloader or in downstream fittings. Inspect all high pressure lines (including gun and hose) for any signs of leakage and repair as necessary.
- * Non-return valve. (within the unloader) damaged, obstructed or worn. Inspect and replace as necessary. Replace with #70-0244.

PRESSURE SWITCH (22-0171)

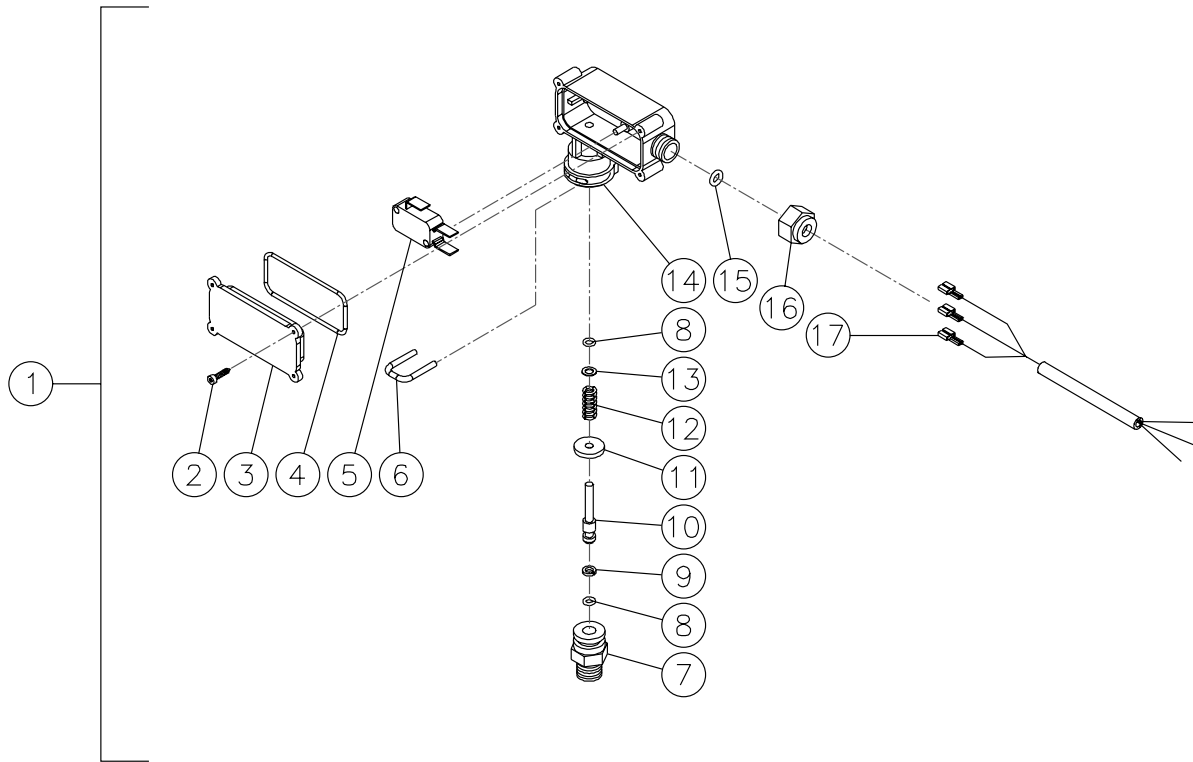

22-0171-120799-BAR

PRESSURE SWITCH (22-0171)			
REF. #	DESCRIPTION	PART #	QTY.
1	Pressure Switch	22-0171	1
2	Screw	N/A	4
3	Cover	N/A	1
4	O-ring (See 70-0306)	N/A Sep.	1
5	Micro Switch	N/A	1
6	Retainer Clip	N/A	1
7	Body	N/A	1
8	O-ring (See 70-0306)	N/A Sep.	2
9	Back-up Ring (See 70-0306)	N/A Sep.	1
10	Piston	N/A	1
11	Washer	N/A	1
12	Spring	49-0144	1
13	Washer	N/A	1
14	Plastic Housing	N/A	1
15	O-ring (See 70-0306)	N/A Sep.	1
16	Nut	N/A	1
17	Wire Assembly	N/A	1
	O-ring Repair Kit (Inc. 4, 8-9, 15)	70-0306	

22-0171-120799-BAR

OMGEN284-052898-DCE

DETERGENT INJECTOR (50-0052)

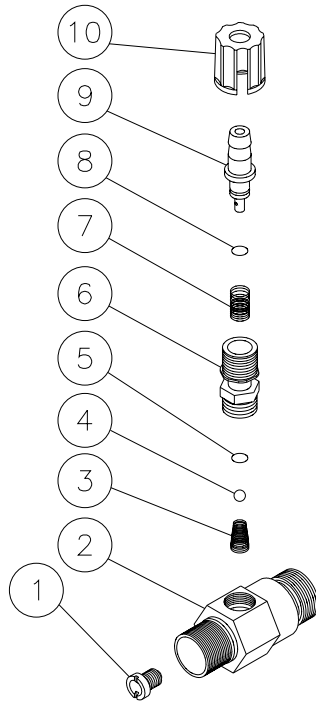

OMGEN284-052898-DCE

DETERGENT INJECTOR (50-0052)			
REF. #	DESCRIPTION	PART #	QTY.
1	Orifice (2.1mm)	50-0057	1
2	Injector Body	N/A	1
3	Spring (See 852-0056)	N/A Sep.	1
4	Ball (See 852-0056)	N/A Sep.	1
5	O-ring (See 852-0056)	N/A Sep.	1
6	Piston Retainer	50-0156	1
7	Spring	49-0056	1
8	O-ring (See 852-0056)	N/A Sep.	1
9	Adjustable Shutter Barb	50-0157	1
10	Adjustment Knob	50-0158	1
	Injector Repair Kit (Includes 3-5, 8)	852-0056	

COIL DRAIN PLUG (850-0218)

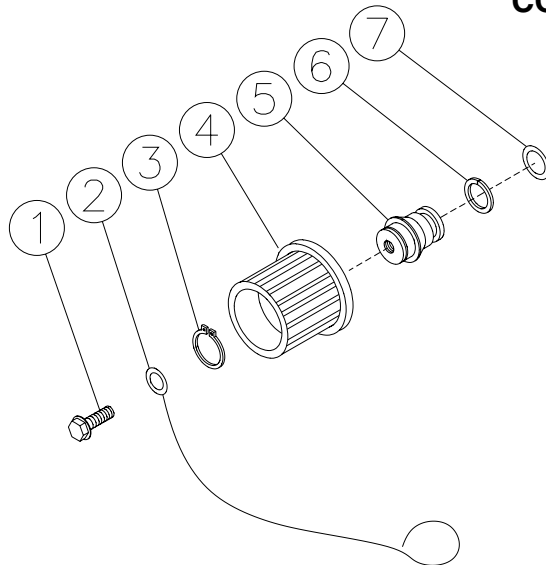

850-0218-041597-BAR

COIL DRAIN PLUG (850-0218)			
REF. #	DESCRIPTION	PART #	QTY.
1	Bolt	27-9526	1
2	Retaining Cable	33-0260	1
3	Snap Ring	33-0261	1
4	Hand Wheel	16-0239	1
5	Plug	24-0147	1
6	Back-up Ring	25-0424	1
7	O-ring	25-0423	1

850-0218-041597-BAR

HEAT EXCHANGER/ EMF SYSTEM

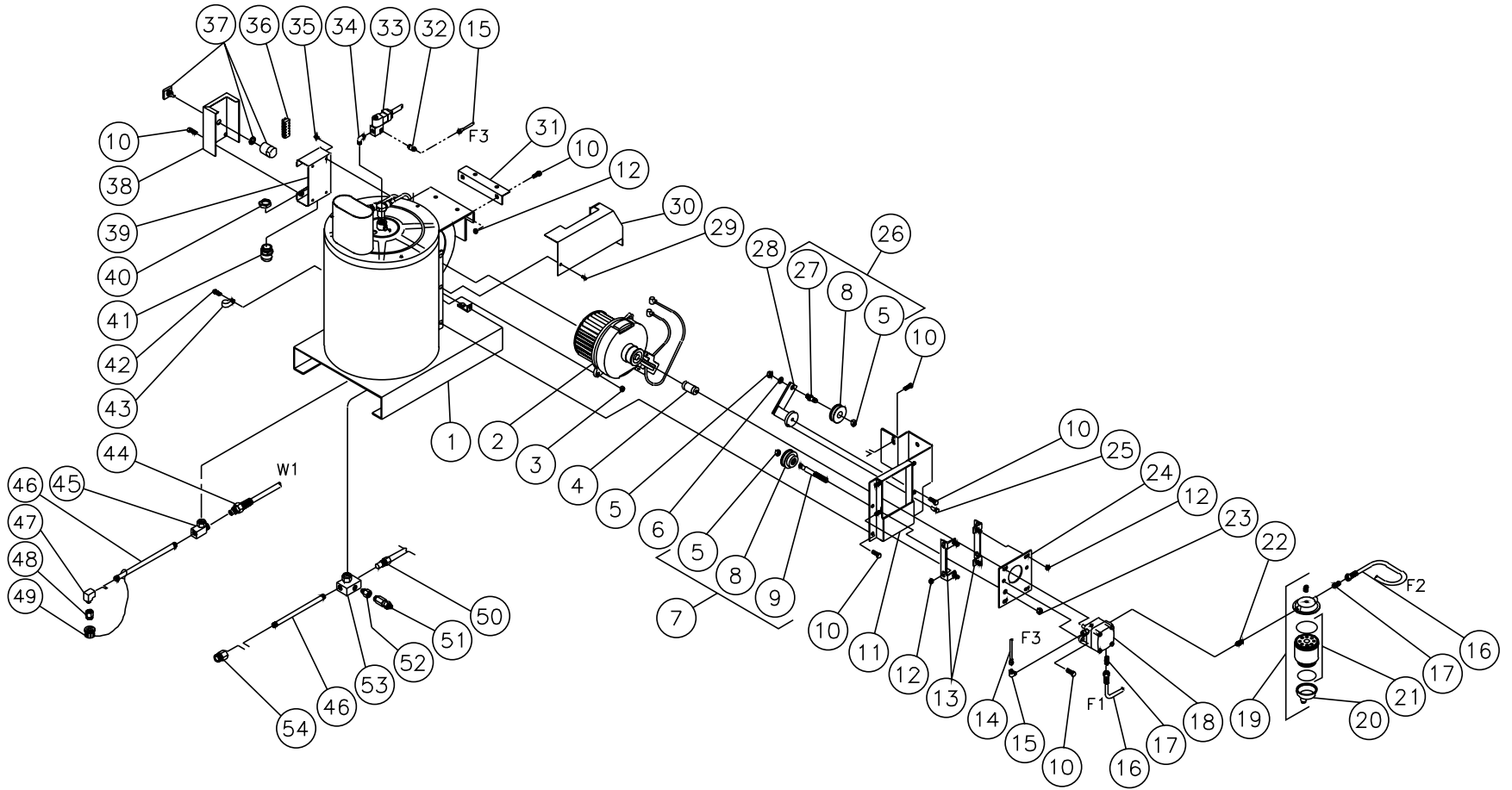

HSP098-022299-BAR

HEAT EXCHANGER/ EMF SYSTEM									
REF. #	DESCRIPTION	PART #	QTY. 3MGH	QTY. 3MGV	REF. #	DESCRIPTION	PART #	QTY. 3MGH	QTY. 3MGV
1	Boiler Assembly Complete	850-0224	1	1	29	Bolt	27-9526	2	2
2	EMF Assembly	850-0239	1	1	30	Beltguard- Honda	20-0362A01	1	-
3	Hex Nut	30-3022	2	2	-	Beltguard- Vanguard	20-0355A01	-	1
4	Fuel Pump Coupler	33-0225	1	1	31	Bracket	20-0354A01	-	1
5	Nut	30-0159	3	3	32	Connector	23-0291	1	1
6	Flatwasher	28-0022	1	1	33	Solenoid- 12 Volt	44-0098	1	1
7	Adjustable Sheave Shaft Assembly (Inc. 5, 8, 9)	850-0167	1	1	34	Elbow	23-0249	1	1
8	Sheave Assembly	850-0177	2	2	35	Bolt	27-9528	4	4
9	Pulley	33-0221	1	1	36	Terminal Stripe *(One Foot Required)	32-0394	1	1
10	Bolt	27-9524	11	13	37	Switch Cam	32-0399	1	1
11	Bracket/ Fuel Pump- Black	20-0353A01	1	1	38	Cover Electric Box- Black	20-0357A01	1	1
12	Hex Nut	30-3023	8	10	39	Backplate Electric Box- Black	20-0356A01	1	1
13	Bracket- Black	20-0360A01	2	2	40	Electrical Locknut	32-0292	1	1
14	Fuel Line	33-0217	1	1	41	Strain Relief	9-0046	1	1
15	Elbow	23-0248	1	1	42	Screw	27-3062	1	1
16	Fuel Hose	15-0147	2	2	43	Cable Clamp	32-0428	1	1
17	Connector	23-0247	2	2	44	High Pressure Hose Assembly	15-0199	1	1
18	Fuel Pump	3-0129	1	1	45	Coil Inlet Connector Assembly	850-0225	1	1
19	Filter Fuel Water Seperator	19-0070	1	1	46	Nipple	24-0122	2	2
20	Fuel Water Seperator Replacement Bowl	19-0071	1	1	47	Elbow	23-0306	1	1
21	Fuel Water Seperator Replacement Filter	19-0053	1	1	48	Adapter	23-0279	1	1
22	Hex Nipple	23-0250	1	1	49	Drain Plug Assembly	850-0218	1	1
23	Hex Nut	30-0010	1	1	50	High Limit Switch Probe	32-0421	1	1
24	Plate- Black	20-0363A01	1	1	51	Pressure Relief Valve	22-0272	1	1
25	Pin	33-0211	1	1	52	Adapter Coil Outlet	23-0369	1	1
26	Tensioner Sheave Shaft Assembly (Inc. 5, 8, 27)	850-0166	1	1	53	Coil Outlet Assembly	850-0251	1	1
27	Shaft	33-0212	1	1	54	Hex Reducer	23-0197	1	1
28	Tensioner Base	10-0071	1	1	*Must Order in One Foot Lengths				

BOILER ASSEMBLY (850-0224)

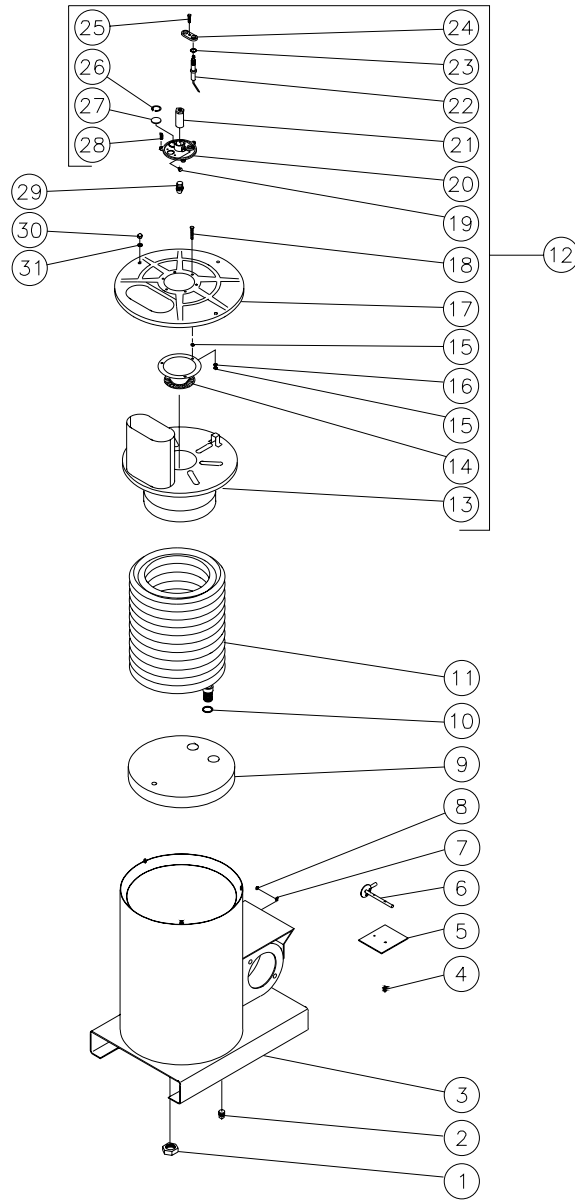

ELECTRODE GAP SETTINGS

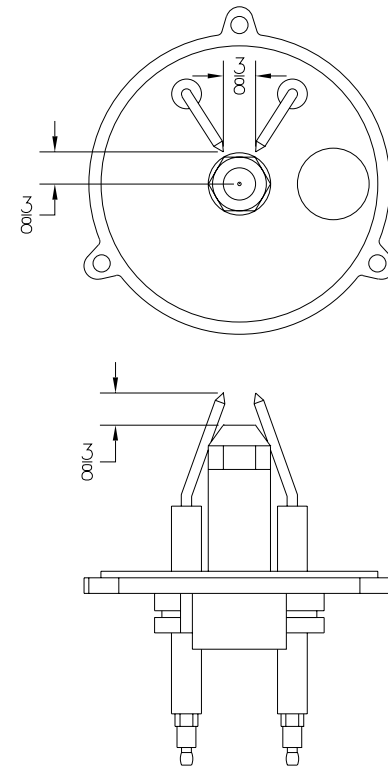

BOILER ASSEMBLY (850-0224)								
REF. #	DESCRIPTION	PART #	QTY.		REF. #	DESCRIPTION	PART #	QTY.
1	Hex Nut	30-6004	2		17	Top Pan	20-0323	1
2	Plug	24-0034	1		18	Bolt	27-8806	3
3	Heat Exchanger Assembly- Black	20-0348A01	1		19	Bolt	27-8805	1
4	Bolt Hex Head	27-8879	2		20	Support Plate	33-0183	1
5	Air Diverter Plate- Black	20-0454A01	1		21	Nozzle Holder	33-0182	1
6	Air Diverter Stem Assembly- Black	20-0377A01	1		22	Electrode	32-0377	2
7	Lockwasher	28-1009	1		23	Washer	28-1007	2
8	Nut	30-6001	1		24	Electrode Mounting Plate	33-0180	1
9	Insulation	33-0267	1		25	Bolt	27-8807	1
10	Washer	28-0521	2		26	Snap Ring	25-0290	1
11	Heat Exchanger Coil Assembly	66-0010	1		27	Sight Glass	33-0179	1
12	Pan Assembly (Includes 13-28)	70-0184	1		28	Bolt	27-8803	3
13	Exhaust Pan	20-0324	1		29	Fuel Nozzle	18-0310	1
14	Heat Deflector	20-0325	1		30	Nut	30-6002	3
15	Nut	30-6001	6		31	Washer	28-1028	3
16	Lockwasher	28-1009	3			Boiler Assembly Complete (Inc. 1-28, 30, 31)	850-0224	1

GUN (850-0179) & ADJUSTABLE PRESSURE DUAL LANCE (850-0185)

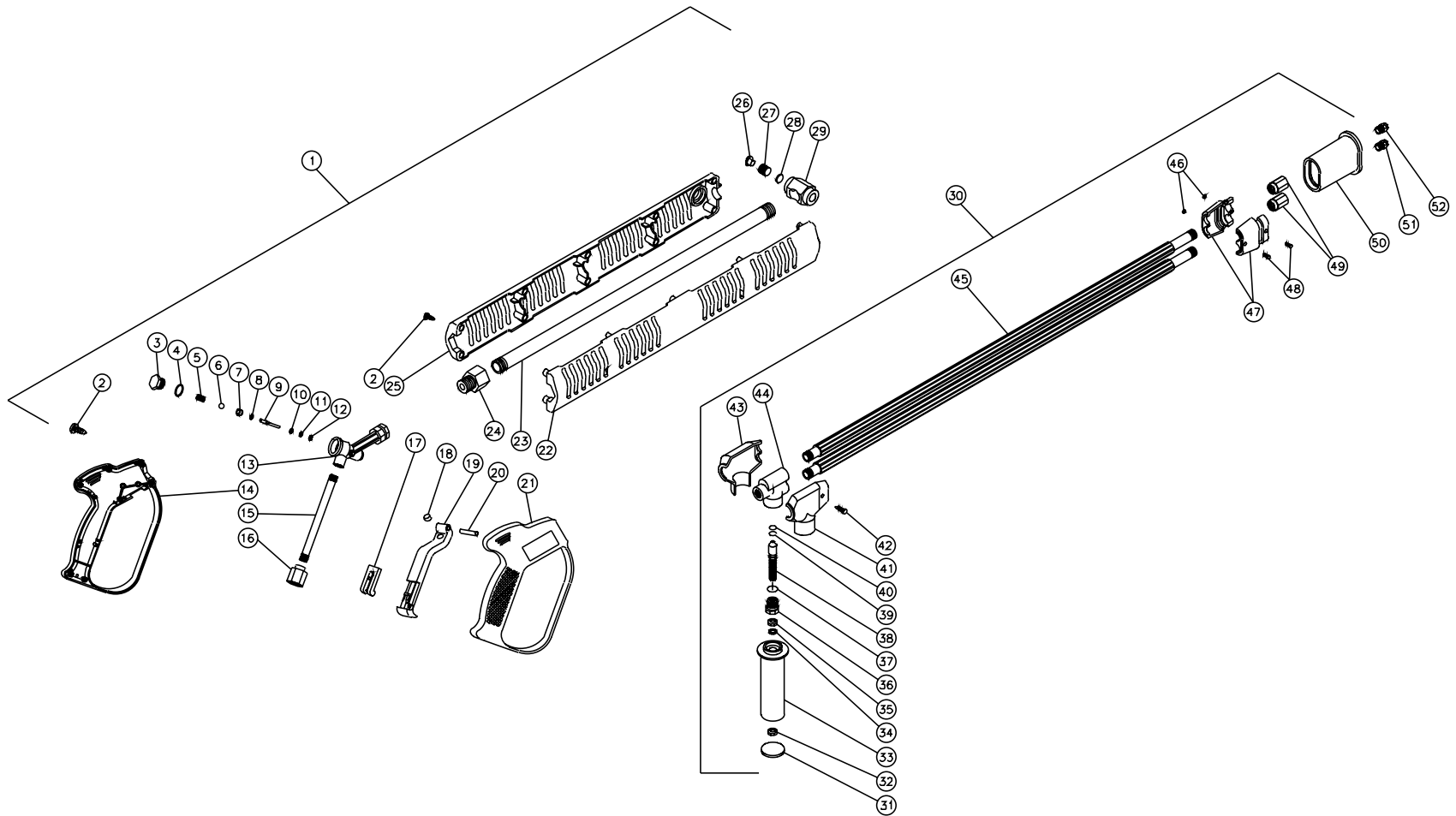

OMGEN256-022399-BAR

GUN (850-0179) & ADJUSTABLE PRESSURE DUAL LANCE (850- 0185)							
REF. #	DESCRIPTION	PART #	QTY.	REF. #	DESCRIPTION	PART #	QTY.
1	Gun w/Lance Assembly (Includes 2-29)	850-0179	1	28	Spacer	16-0282	1
2	Screw	27-8382	13	29	Lance Holder (See 850-0179)	N/A Sep.	1
3	Plug (See 70-0057)	N/A Sep.	1	30	Adjustable Dual Lance Assembly (Includes 31-51)	850-0185	1
4	O-ring (See 70-0057)	N/A Sep.	1	31	Handle Plug	16-0312	1
5	Spring (See 70-0057)	N/A Sep.	1	32	Hex Nut	30-3002	1
6	Ball (See 70-0057)	N/A Sep.	1	33	Handle	16-0313	1
7	Seat (See 70-0057)	N/A Sep.	1	34	Washer	28-1021	1
8	O-ring (See 70-0057)	N/A Sep.	1	35	Hex Nut	30-3010	1
9	Pin (See 70-0057)	N/A Sep.	1	36	Hex Adapter	23-0271	1
10	Washer (See 70-0057)	N/A Sep.	1	37	O-ring	25-0351	1
11	O-ring (See 70-0057)	N/A Sep.	1	38	Piston Stem	16-0314	1
12	Back-up Ring (See 70-0057)	N/A Sep.	1	39	Back-up Ring	25-0352	1
13	Housing	23-0295	1	40	O-ring	25-0353	1
14	Plastic Housing (Left Side)	16-0336	1	41	Screw	27-8862	1
15	Pipe	21-0095	1	42	Upper Protector	16-0315	1
16	Nipple	23-0174	1	43	Lower Protector	16-0316	1
17	Trigger Safety Lock	16-0332	1	44	Body	23-0272	1
18	Trigger Rest	16-0333	1	45	Lance w/Protective Cover	16-0328	2
19	Trigger	16-0335	1	46	Hex Nut	30-3060	2
20	Trigger Pin	43-0069	1	47	Pipe Clamp	16-0318	2
21	Plastic Housing (Right Side)	16-0334	1	48	Screw	27-8861	2
22	Guard Lance (Right Side)	16-0279	1	49	Nipple	24-0127	2
23	Pipe	16-0277	1	50	Nozzle Protector	16-0319	1
24	Adapter	16-0283	1	51	Nozzle-4060	18-0110	1
25	Guard Lance (Left Side)	16-0278	1	52	Nozzle-1503	18-0053	1
26	Plug	39-0076	1		Gun Repair Kit (Includes 3-12)	70-0057	
27	Screw	49-0103	1		O-ring Kit (Includes 37, 39, 40)	70-0143	

FUEL TANK (850-0214)

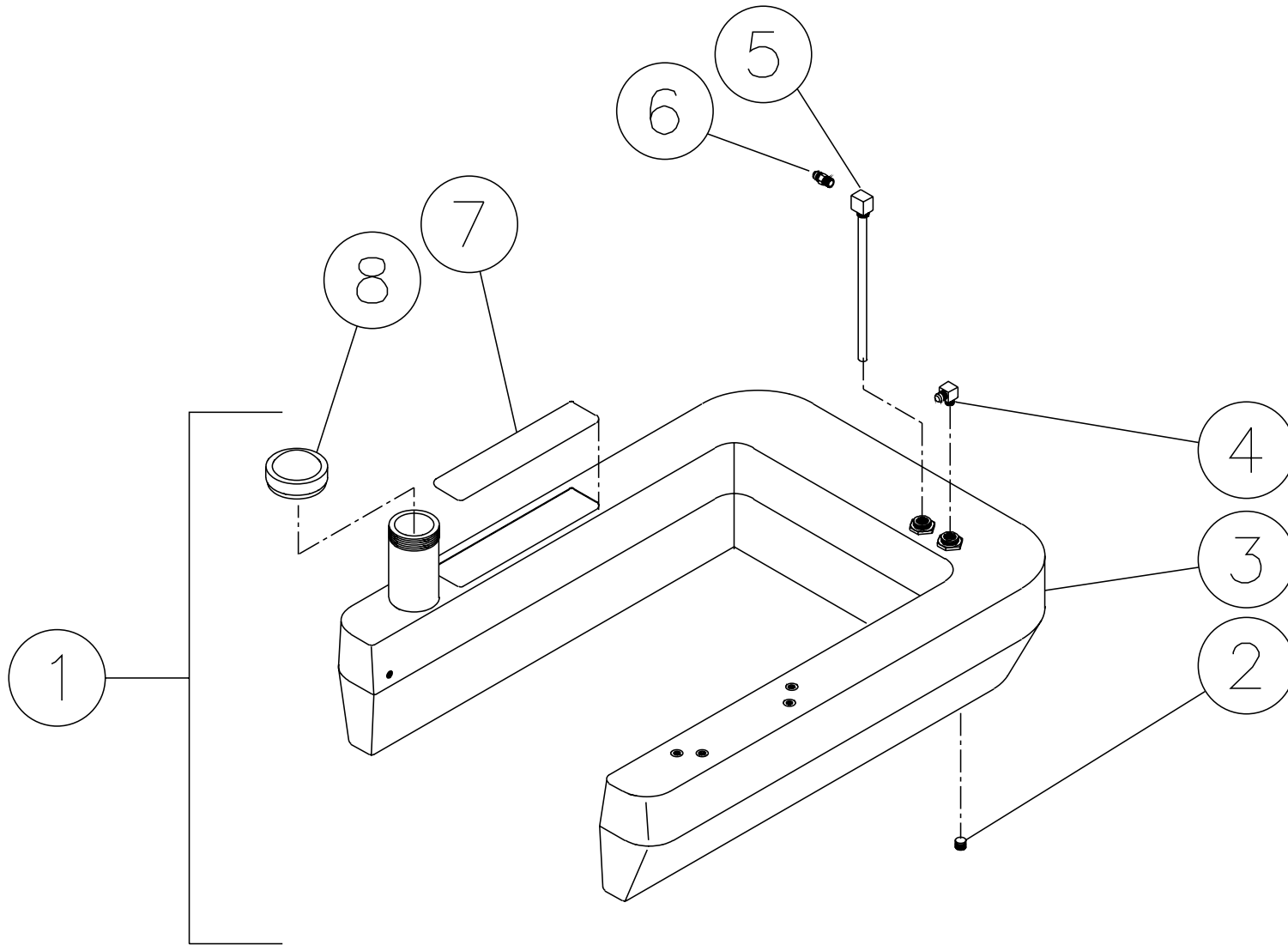

850-0214-121797-BAR

FUEL TANK (850-0214)			
REF. #	DESCRIPTION	PART #	QTY.
1	Fuel Tank Assembly (Inc. 2-8)	850-0214	1
2	Plug	23-0296	1
3	Fuel Tank (See 850-0214)	N/A Sep.	1
4	Elbow	23-0237	1
5	Fuel Pick-up Line	33-0270	1
6	Flare	23-0247	1
7	Decal-Warning-Risk of Fire (E/S)	34-0806	1
8	Fuel Cap-Vented	12-0033	1

FUEL PUMP (3-0129)

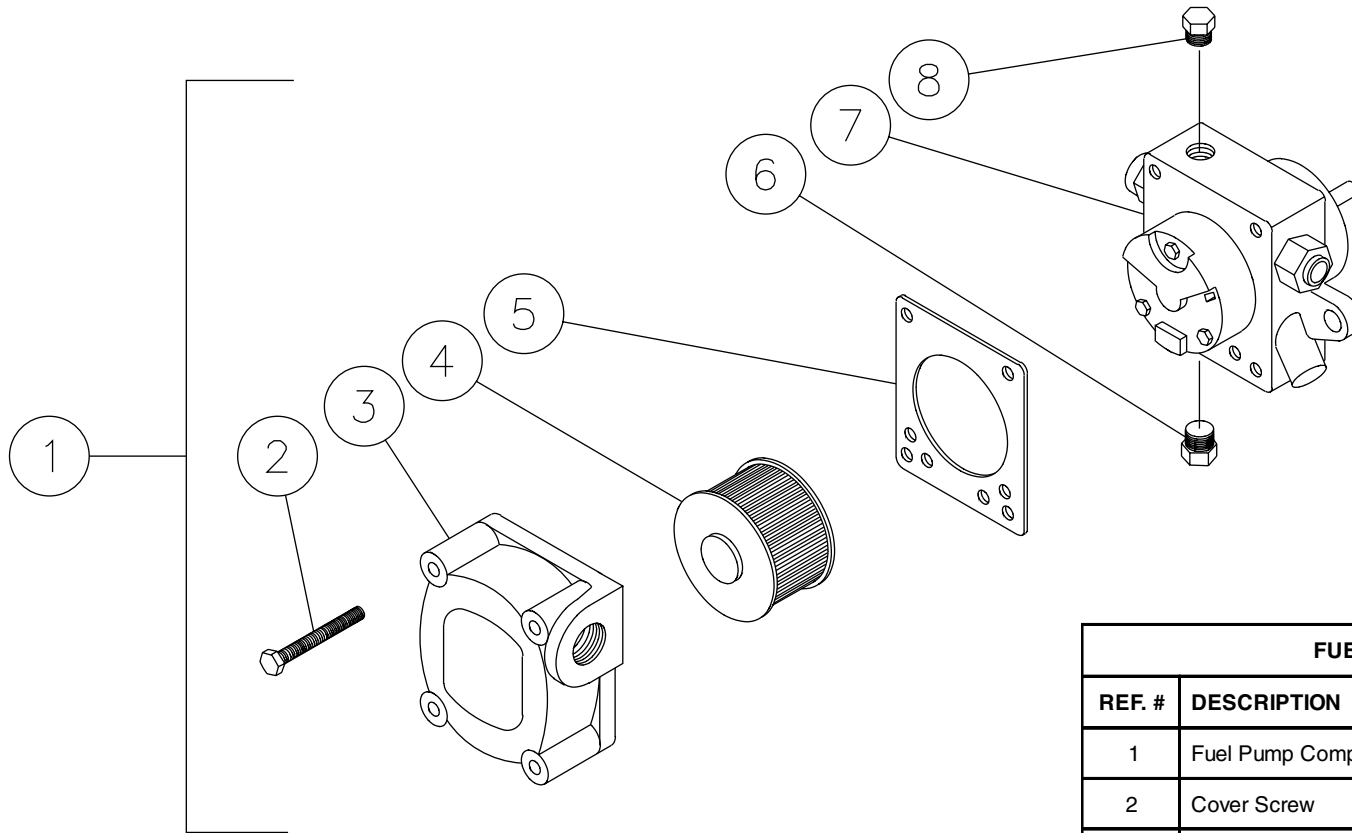

0MHSP018-041597-BAR

FUEL PUMP (3-0129)			
REF. #	DESCRIPTION	PART #	QTY.
1	Fuel Pump Complete (Includes 2-8)	3-0129	1
2	Cover Screw	46-1006	4
3	Cover-Left Hand	46-1018	1
4	Strainer	19-0034	1
5	Cover Gasket	26-0109	1
6	Plug	24-0044	3
7	Body	N/A	1
8	Plug	24-0082	1

FUEL SOLENOID (44-0098)

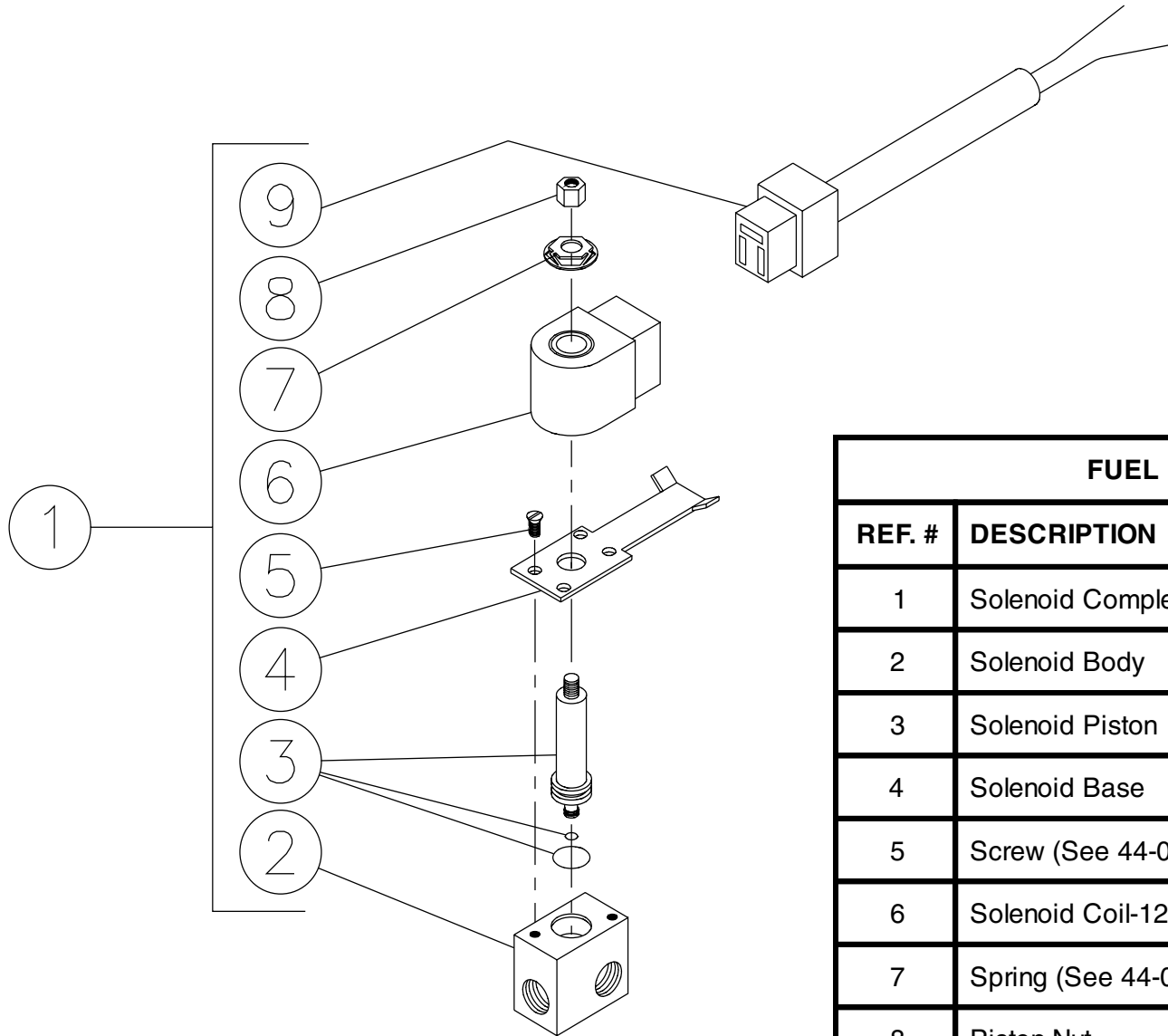

OMHSP013-44-0098-121698-BAR

FUEL SOLENOID (44-0098)			
REF. #	DESCRIPTION	PART #	QTY.
1	Solenoid Complete-12V	44-0098	1
2	Solenoid Body	46-1013	1
3	Solenoid Piston	46-1012	1
4	Solenoid Base	46-1014	1
5	Screw (See 44-0098)	N/A Sep.	2
6	Solenoid Coil-120V	46-1015	1
7	Spring (See 44-0098)	N/A Sep.	1
8	Piston Nut	46-1016	1
9	Din Connector Cord	32-0443	1

EMF SYSTEM (850-0239)

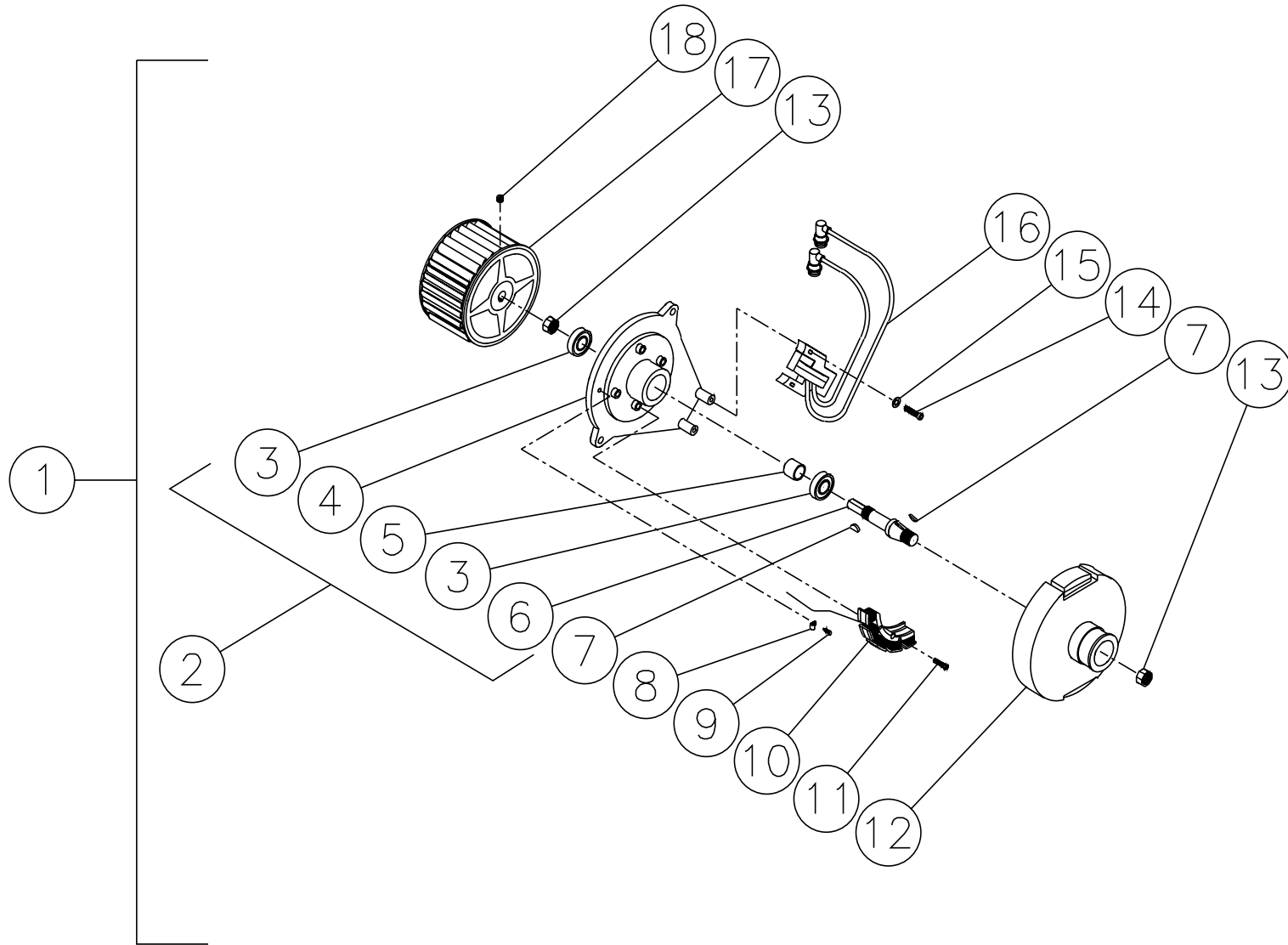

850-0239-113099-BAR

EMF SYSTEM (850-0239)			
REF. #	DESCRIPTION	PART #	QTY.
1	EMF Assembly Complete (Inc. 2-17)	850-0239	1
2	Blower Flange Assembly (Inc. 3-6)	850-0162	1
3	Sealed Bearing	48-0041	2
4	Blower Flange	38-0040	1
5	Spacer	33-0206	1
6	Blower Shaft	20-0347	1
7	Woodruff Key	43-0080	2
8	Cable Clamp	32-0403	1
9	Screw	27-2070	1
10	Stator Coil	850-0189	1
11	Screw	27-0740	4
12	Flange Magnet Hub	38-0041	1
13	Hex Nut	30-0177	2
14	Bolt	27-8898	2
15	Flatwasher	28-0002	2
16	Ignition Coil Assembly	850-0161	1
17	Blower Fan	44-0105	1
18	Set Screw	30-3021	1

WIRING SCHEMATIC

SCHEMATIC

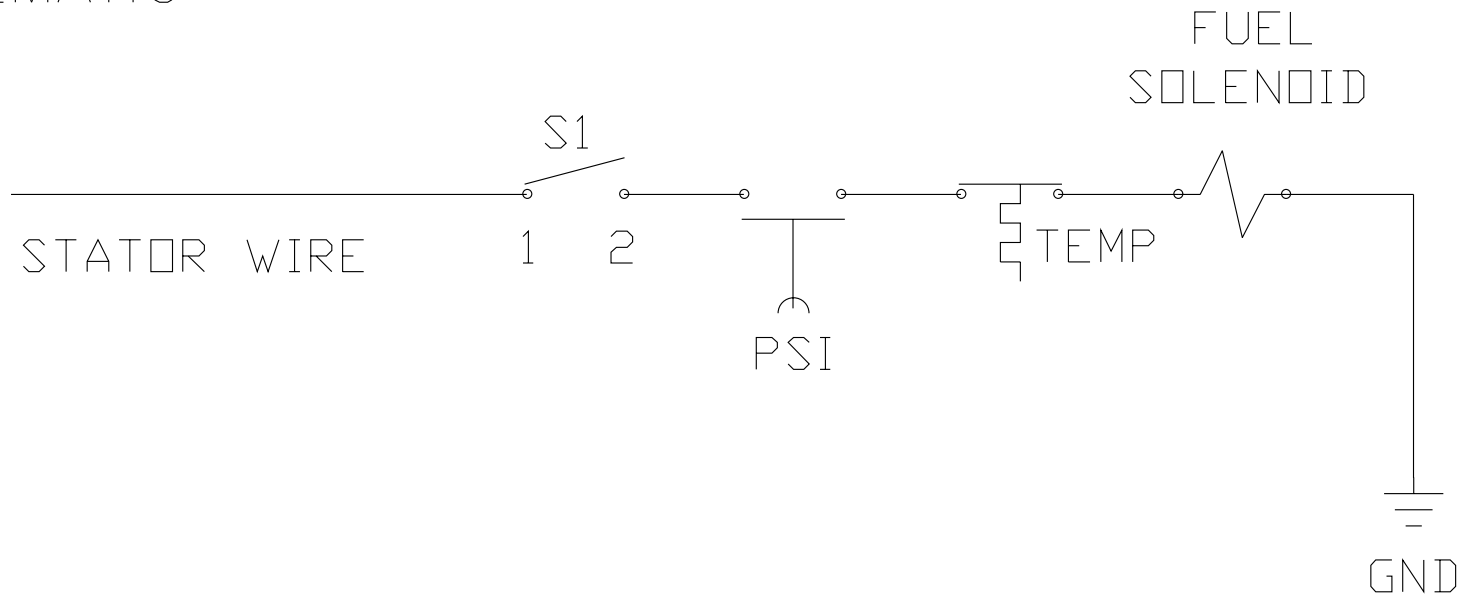

WIRING DIAGRAM

BLACK -----
 BROWN -----
 GREEN -----
 ORANGE -----
 RED -----
 WHITE -----

WIRE DIAGRAM

